

426F2

Backhoe Loader



Cat® 3054C Engine*

Gross Power ISO 14396	68.5 kW (93 hp)
Net Power Rating at 2,200 rpm	66.0 kW (88 hp)

*Emissions equivalent to EU Stage II.

Weights

Operating Weight	8425 kg
------------------	---------

Backhoe Digging Depth

Dig Depth	4709 mm
-----------	---------

426F2 Features

Cab and Controls

The all new cab on the Cat Backhoe Loader provides a comfortable and easy to use operator environment with excellent visibility.

Powerful Hydraulics

The F2 Series Backhoe Loader really makes an impact. High pump flow in a superior hydraulic system delivers excellent hydraulic performance at the operator's fingertips.

Product Link™

Product Link helps you to get the most from your Cat Backhoe Loader, providing remote reporting of machine information such as location and hours.



Contents

Operator Station.....	4
Power Train.....	5
Loader Performance.....	6
Backhoe Performance.....	7
Power and Efficiency	8
Serviceability.....	9
Customer Support.....	10
Specifications.....	11
Standard and Optional Equipment	14
Notes.....	15



Caterpillar has a well proven history in the construction equipment industry and has been producing the highest quality machines for 90 years, making progress possible and driving positive and sustainable change on every continent. For over 35 years, from the A Series to the new F2 Series we have produced Backhoe Loaders that are designed with the operator in mind, providing reliability, power and a quality operator environment. The Cat 426F2 Backhoe Loader continues this tradition, providing a machine to help you grow your business.



Operator Station

Everyone can get comfortable in this cab.

All Day Comfort

The all new 426F2 cab is designed to provide maximum comfort, ease of operation and overall style for today's demanding operator. The new design features a spacious interior, flat glass and excellent visibility. The cab is wider allowing the operator to freely move when turning from one mode of operation to another.

Excellent ergonomics ensure that all controls are within easy reach of the operator. Other features include additional storage space, large vents throughout the cab and clear gauges that provide information to the operator to help maximize the machine's performance. Tinted glass is offered as standard.



Power Train

Powerful performance.

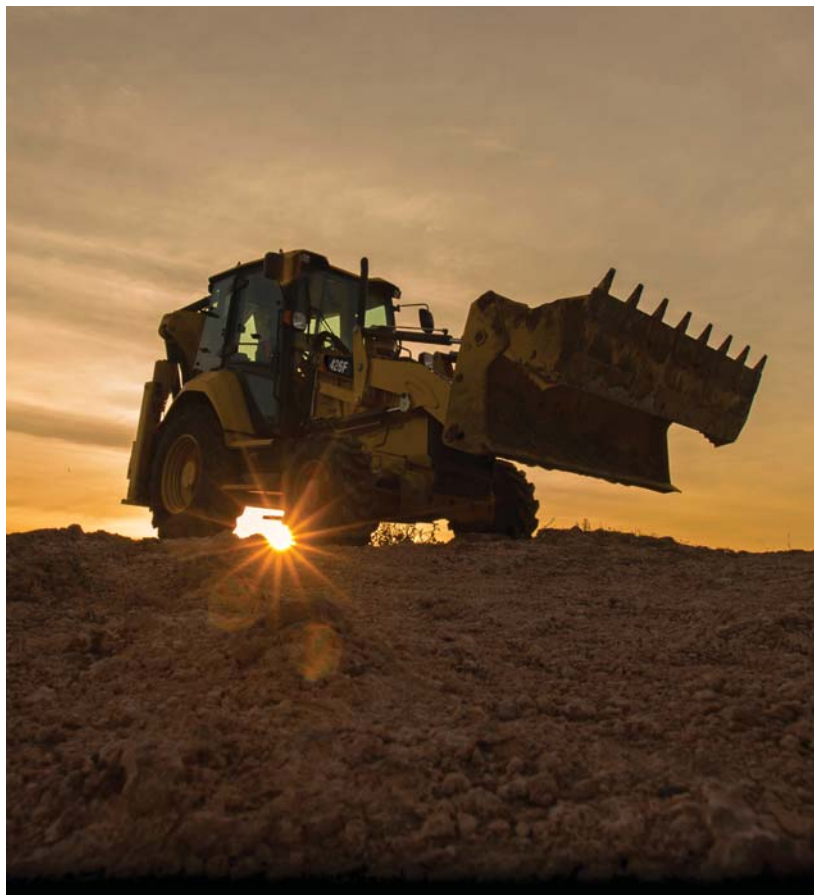

Power Train

The 426F2 features the Cat 3054C engine. The engine is a four cylinder, four stroke direct injection turbo, equipped with standard glow plug starting for optimal cold weather performance. This provides reliable starting performance down to -26°C . The engine also features a gear driven water pump, providing better reliability than conventional belt driven technology.

Axle and Brakes

The 426F2 rear axle is an enclosed design with a wet multi-plate braking system. The system is oil immersed and self-adjusting, and allows operation in the harshest environments. The system has dual brake pedals for split braking in tight corners.

The All Wheeled Drive (AWD) is engaged via a front console panel switch or by the brake pedal during all-wheel-braking operation. The AWD can be engaged on the move, under load, in any gear and in forward or reverse.

The AWD front axle is pendulum mounted and permanently sealed and lubricated, requiring no daily maintenance.

Transmission

The 426F2 comes equipped with a 40 km/h Power-Shuttle transmission, improving roading speed and providing better spacing between gear ratios. The forward/reverse lever on the steering column is placed for easy directional changes on the move, and the gear selection is from a floor mounted shift lever.

Loader Performance

Parallel lift and superior breakout forces.



Parallel Lift

The 426F2 parallel lift loader boasts class leading lift capacities and breakout forces, providing more power and greater productivity.

Available with either a General Purpose or Multi-Purpose bucket, the 426F2 can be matched precisely to your needs. The proven design of the F2 loader makes light work of lifting and loading.

The parallel lift loader arms offer excellent forward visibility along with outstanding material retention throughout the lift and lower cycles.





Backhoe Performance

Versatile design for any application.



Excavator Style Boom

Caterpillar's instantly recognizable boom is more than a cosmetic design feature, it also outperforms straight boom designs too. Whether close-up truck loading on a narrow highway or digging over obstacles such as walls, the excavator style boom outperforms the rest.



Combine this versatility with powerful breakout forces and the controllability of the load-sensing, flow sharing hydraulic system and you have the best boom and stick combination in the industry. Additionally our system offers swing and boom cushioning as standard. This feature enables very fast trenching by damping the boom on lift or swing while trenching.

Power and Efficiency

Load-sensing system delivers improved fuel economy.



Hydraulic Performance

It's rare that you'll be working at full production 100% of the time, so why should the machine be working at full capacity, using more fuel, making more noise and generally increasing wear and tear on key components? The 426F2 has a load-sensing, closed center hydraulic system, which is designed to closely match power and flow to the demand needed by the operation.

So whether you're in full trenching mode, or delicately digging around services, you are always in total control. In applications such as loading and carrying speed is important. The system will match the flow needed to get the job done quickly and efficiently. As there is minimal demand on the system unless needed, there are less parasitic horsepower losses and more power available for rimpull which means better loading and roading performance.

The 426F2 also features flow-sharing hydraulic valves, ensuring that the correct flow of oil reaches the implement cylinders, providing greater control and eliminating oil starvation when operating multiple functions, such as grading with the backhoe.

Serviceability

Easy service to keep your machine working.



Easy Access

The 426F2 is equipped with a flip open hood, allowing access to all the check and fill points, air cleaner, washer bottle and visual check indicators. The hinged cooling pack provides easy access to not only the radiator and air conditioner, but also the transmission and hydraulic cooler.

The 426F2 carries on the Cat Backhoe Loader tradition with sealed for life axle oscillating pins, axle and driveshaft U-joints. Daily checks that can be time consuming for a busy operator are kept to a minimum on the 426F2.

Cat Product Link™ system provides remote reporting of machine location and hours.



Customer Support

Unrivalled customer support network.

Renowned Cat Dealer Support

From helping you choose the right machine to knowledgeable ongoing support, Cat dealers provide the best in sales and service.

- Preventive maintenance programs and guaranteed maintenance contracts
- Best-in-class parts availability
- Operator training to help boost your profits
- Genuine Cat Remanufactured parts



Customer Support Agreements

Your Cat dealer can offer a comprehensive range of Customer Support Agreements (CSA) that can be individually tailored to suit your finances and requirements. Dealers can offer a range of options from a full preventive maintenance with S•O•SSM package to a parts only CSA. Protect your valuable investment and know exactly what your monthly payments will be to help you run your business.

Finance

Have you explored the range of options available from your dealer to finance your machine? They can offer a selection of attractive packages tailored to suit your every requirement.

Machine Selection

Your dealer can help you with your machine purchase decision, based on your requirements and help keep operating costs to a minimum. Is the machine you have in mind exactly the best for your job or could there be a more suitable solution?

Training and Support

Speak to your dealer about additional support. They can advise you on operating techniques for your machine that will minimize wear and tear, maximize productivity, lower owning and operating costs and help you make the most of the fantastic features offered on the Cat Backhoe Loader.

426F2 Backhoe Loader Specifications

Engine

Model	Cat 3054C Mechanical Turbo
Rated Power (standard) @ 2,200 rpm	
Gross Power ISO 14396	68.5 kW (93 hp)
Net Power Rating @ 2,200 rpm	
ISO 9249	66.0 kW (88 hp)
Torque Rise (net) @ 1,200 rpm	38%
Maximum Torque @ 1,400 rpm	394 N·m
Bore	105 mm
Stroke	127 mm
Displacement	4.4 L

- Net power advertised is the power available at the flywheel when the engine is equipped with fan, air cleaner, muffler and alternator.
- No derating required up to 2286 m altitude. Auto derate protects hydraulic and transmission systems.
- Emissions equivalent to EU Stage II.

Hydraulic System

Type	Closed Center
Pump Type	Variable Flow, Axial Piston
Maximum Pump Capacity	132 L/min
System Pressure	
Backhoe	250 Bar
Loader	250 Bar

Noise Level

Inside Cab	80 dB(A)
Outside Cab	104 dB(A)

Transmission

Travel speeds of Two Wheel Drive backhoe loader at full throttle, when equipped with 16.9×28 rear tires.

	Power Shuttle
Forward	
1st	5.6 km/h
2nd	9.3 km/h
3rd	21.0 km/h
4th	40.0 km/h
Reverse	
1st	5.6 km/h
2nd	9.3 km/h
3rd	21.0 km/h
4th	40.0 km/h

Service Refill Capacities

Cooling System	22.0 L
Fuel Tank	160 L
Engine Oil with Filter	8.8 L
Transmission (Power Shuttle)	
AWD	15 L
Rear Axle	16.5 L
Planetaries	1.7 L
Front Axle (AWD)	11 L
Planetaries	0.7 L
Hydraulic System	106 L
Hydraulic Tank	40 L

Weights*

Operating Weight (estimated)	8425 kg
Operating Weight (Maximum) (ROPS Capacity)	11 000 kg
Counterweights	
Base	115 kg
Medium	240 kg
Minimum Counterweight Recommendations – Standard Stick	
Loader Bucket – GP	115 kg
Loader Bucket – MP	0 kg

*Machine Configuration – standard engine, standard stick hoe, standard cab with A/C, AWD standard shift transmission, 0.96 m³ MP loader bucket, 24 inch standard duty hoe bucket, 12.5/80-18 and 16.9-28 tires, no counterweight, 80 kg operator and full fuel tank.

Axles

All Wheel Drive (AWD)

Features

- Heavy-duty rear axle with self adjusting inboard brakes, differential lock and final drives.
- AWD is engaged by front console panel switch or by brake pedal during all-wheel-braking operation. AWD can be engaged on the move, under load, in any gear, forward or reverse. AWD has outer final drives for easy maintenance.
- AWD front axle is pendulum mounted and permanently sealed and lubricated, requiring no daily maintenance. Also features double-acting steering cylinder with 52° steering angle for increased maneuverability.

Axle Ratings

Front Axle, AWD	
Static	22 943 kg
Dynamic	9177 kg
Rear Axle	
Static	22 964 kg
Dynamic	9186 kg

426F2 Backhoe Loader Specifications

Steering

Type	Front Wheel
Power Steering	Hydrostatic
AWD Cylinder, One (1) Double-acting	
Bore	65 mm
Stroke	120 mm
Rod Diameter	36 mm

Turning Circle

AWD (inner wheel not braked)	
Outside Front Wheels	8.18 m
Outside Widest Loader Bucket	10.97 m

Brakes

Fully enclosed boosted, hydraulic, multiple discs.

Features

- Inboard oil-immersed, hydraulically actuated multiple Kevlar discs on final drive input shaft.
- Completely enclosed and sealed.
- Self-adjusting.
- Dual foot-operated boosted brake pedals can be interlocked for roading.
- Parking/secondary brakes are independent of the service brake system. Parking brake is mechanically applied through a hand lever located in the right side console.
- Meets ISO 3450:1996 requirements.

Machine Dimensions

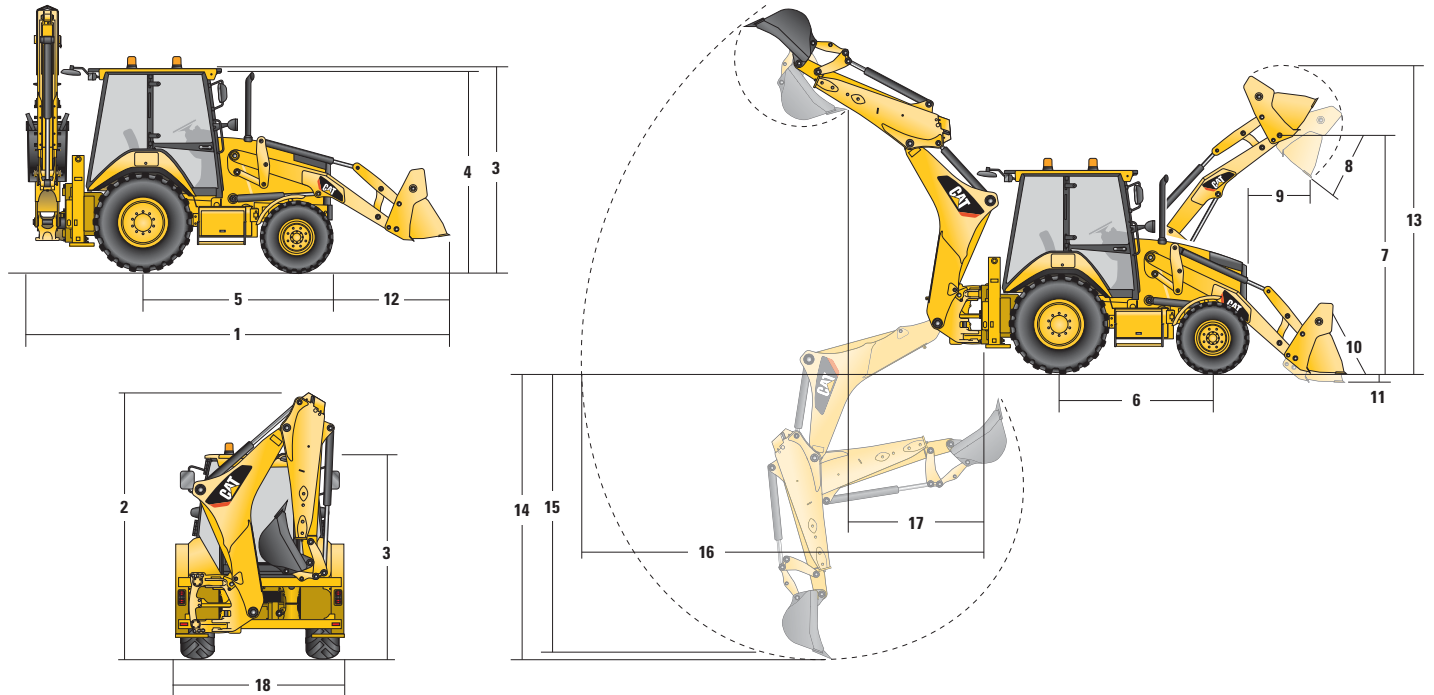

	GP – 1.05 m ³	MP – 0.96 m ³
1 Overall Length in Roading Position	5726 mm	5682 mm
Overall Transportation Length	5678 mm	5675 mm
2 Overall Transportation Height – 4.3 m	3757 mm	3757 mm
Overall Width (excluding loader bucket)	2346 mm	2346 mm
3 Height to Top of Cab/Canopy	2869 mm	2869 mm
4 Height to Top of Exhaust Stack	2716 mm	2716 mm
5 Rear Axle Centerline to Front Grill	2708 mm	2708 mm
6 Wheelbase AWD	2200 mm	2200 mm

Dimensions and performance specifications shown are for machines equipped with 12.5/80-18 front tires, 16.9-28 rear tires, standard cab, standard stick with 24 inch standard duty bucket, and 1.05 m³ GP loader bucket and standard equipment unless otherwise specified.

426F2 Backhoe Loader Specifications

Loader Bucket Dimensions and Performance

	GP – 1.05 m ³	MP – 0.96 m ³
Capacity	1.05 m ³	0.96 m ³
Width	2262 mm	2262 mm
Lift Capacity at Maximum Height	3610 kg	3475 kg
Lift Breakout Force	54.46 kN	54.0 kN
Tilt Breakout Force	53.92 kN	60.48 kN
Tipping Load at Breakout Point	7012 kg	7110 kg
7 Maximum Hinge Pin Height	3447 mm	3447 mm
8 Dump Angle at Full Height	46°	46°
Dump Height at Maximum Angle	2733 mm	2764 mm
9 Dump Reach at Maximum Angle	900 mm	825 mm
10 Maximum Bucket Rollback at Ground Level	38°	39°
11 Digging Depth	88 mm	147 mm
Maximum Grading Angle	113°	116°
12 Grill to Bucket Cutting Edge, Carry Position	1482 mm	1450 mm
13 Maximum Operating Height	4368 mm	4368 mm
Bucket Weight (excluding teeth and forks)	428 kg	611 kg

Backhoe Dimensions and Performance

	Standard Stick – 4.3 m
14 Digging Depth, SAE Maximum	4119 mm
Digging Depth, Manufacturer's Maximum	4709 mm
15 Digging Depth, 2440 mm Flat Bottom	3743 mm
Digging Depth, 600 mm Flat Bottom	4094 mm
Digging Depth, 600 mm Flat Bottom, Manufacturer's	4670 mm
16 Reach from Swing Pivot at Ground Line	5609 mm
Maximum Operating Height	5719 mm
Loading Height	4031 mm
17 Loading Reach	1477 mm
Swing Arc	180°
Bucket Rotation	205°
18 Stabilizer Overall Width	2242 mm
Bucket Dig Force	57.22 kN
Stick Dig Force	35.29 kN

426F2 Standard and Optional Equipment

Standard and Optional Equipment

Standard and Optional equipment may vary. Consult your Cat dealer for details.

	Standard	Optional		Standard	Optional
Cab ROPS and FOPS			Guards		
Canopy	✓	—	Guard, Driveshaft	—	✓
Cab, Standard	—	✓	Loader Safety Brace	✓	—
Tires/Steering/Brakes			Boom Sticks and Linkages – Backhoe		
Two Wheel Drive	✓	—	Stick, Standard (4.26 m)	✓	—
All Wheel Drive	—	✓	Transport Lock, Swing	✓	—
100% Differential Lock	✓	—	Transport Lock, Boom	✓	—
Hydraulic Boosted Brakes (dual pedals)	✓	—	Hydraulics		
Tires 16 inch (Front) – 2WD	✓	—	Hydraulic Pump (132 L/min)	✓	—
Tires 18 inch (Front) – AWD	✓	—	Side Shift Lock (electro-hydraulic)	✓	—
Tires 28 inch (Rear)	✓	—	Hydraulic Oil Cooler	✓	—
Engine/Transmission			Hydraulics – Backhoe		
Battery 750 CCA, Maintenance Free (standard)	✓	—	Hydraulic Lines, 1-Way	—	✓
Hinged Radiator Unit for Simple Debris Removal	✓	—	Hydraulic Quick Disconnects (twist to connect)	—	✓
Engine 68.5 kW (93 hp) Cat 3054C	✓	—	Hydraulics – Loader		
Transmission, 4-Speed Manual	✓	—	Loader Kickout, Float	✓	—
Input			Parallel Lift	✓	—
Controls, Mechanical Lever	✓	—	Electrical		
Power Steering, Hydrostatic	✓	—	Product Link, Cellular	✓	—
Other Attachments			Reversing Alarm	✓	—
Counterweight, 115 kg	—	✓	Beacon, Rotating	—	✓
Counterweight, 240 kg	—	✓			
Tool Storage Box	✓	—			
Transport Tie-downs	✓	—			

For more complete information on Cat products, dealer services, and industry solutions, visit us on the web at www.cat.com

© 2019 Caterpillar
All rights reserved

Materials and specifications are subject to change without notice. Featured machines in photos may include additional equipment. See your Cat dealer for available options.

CAT, CATERPILLAR, LET'S DO THE WORK, their respective logos, "Caterpillar Yellow," the "Power Edge" and Cat "Modern Hex" trade dress as well as corporate and product identity used herein, are trademarks of Caterpillar and may not be used without permission.

AEHQ8036-01 (03-2019)
Replaces AEHQ8036
(Africa, APD, Middle East,
South America)

