

GRW 18

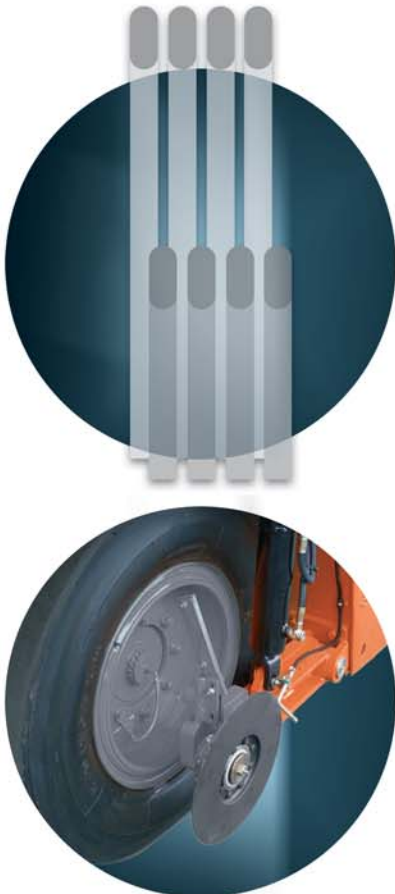

Rubber tired roller

- ▶ Generous 2" tire overlap even at half of the maximum turning angle
- ▶ 4 wheels each, front and rear
- ▶ Dual pivot points on the front axles for increased stability and maneuverability
- ▶ Dipping and oscillating front wheels provide for even ground pressure
- ▶ 3 speed power shift transmission
- ▶ Multiple ballast options
- ▶ Smooth, jerk-free shifting with hydro-dynamic drive (No chain drive)
- ▶ Easy to operate, easy to service

TECHNICAL DATA

GRW 18

GRW 18 - Rubber tired roller

Weights	
Basic weight without ROPS	lbs (kg) 30,830 (13985)
Operating weight with ROPS	lbs (kg) 31,834 (14440)
Maximum weight	lbs (kg) 61,700 (28000)
Wheel load maximum	lbs (kg) 7,700 (3500)
Machine Dimensions	
Working width	in (mm) 78 (1986)
Turning radius, inside	in (mm) 232 (5900)
Turning radius, outside	in (mm) 307 (7800)
Tires, front and rear	11.00 R 20 12 PR
Tire overlap on each side	in (mm) 2.0 (50)
Diesel engine	
Manufacturer	DEUTZ
Model	TCD 2012 L04 2V
Number of cylinders	4
Power rating DIN/ISO30461FN kW/HP/rpm	85,0/115.6/2300
Power rating SAE J1349, HP/kW/rpm	114.0/85,0/2300
Fuel tank, capacity	Gal (Ltr) 52 (198)
Drive	
Hydrodynamic drive	Rear
Speed, 1st gear	mph (km/h) 0-3.2 (0-5,2)
Speed, 2nd gear	mph (km/h) 0-7.1 (0-11,5)
Speed, 3rd gear	mph (km/h) 0-13.1(0-21,2)
Gradeability, with/without ballast	25%/35%
Steering	
Steering, type	Two-point steering
Steering, actuation	hydrostatic, steering wheel
Steering angle +/-	Grad 30°
Oscillation angle +/-	Grad 4°
Brake system	
Service brake, mode of action	Internal shoe brake
Service brake, actuation	Foot brake pedal
Parking brake, mode of action	Belt brake
Parking brake, actuation	Hand brake lever
Emergency brake, mode of action	Belt brake
Emergency brake, actuation	Hand brake lever
Sprinkler system	
Water sprinkler, type	Pressure
Actuation, sprinkling	Manual
Water tank, capacity	Gal (Ltr) 198 (750)

Standard equipment

Operator's platform accessible from either side, hydraulically suspended operator's seat, horn, hour meter, engine oil temperature gauge, air filter restriction indicator, hydraulic oil temperature gauge, lights, 2 mirrors, ROPS.

Optional equipment

Second operator's station. Air on the run, edge pressing roll and cutting disc, tire heating system, winter aprons, comfortable cab with two lockable doors, sun visor, ventilator and heater.

Further data on request / subject to change

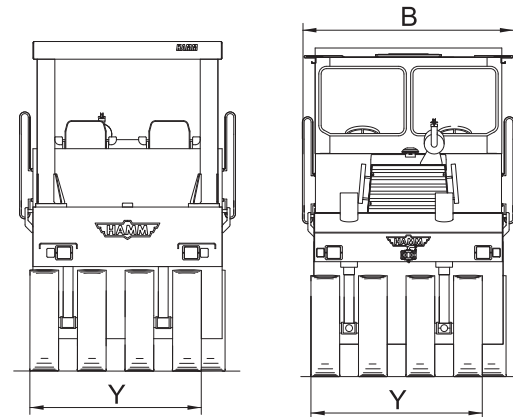
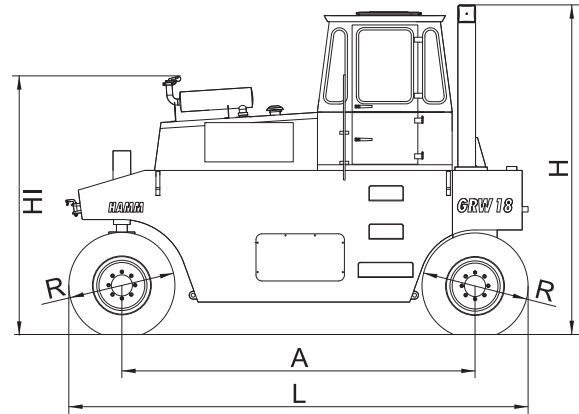

		GRW 18
Total length	L	187" (4745)
Total width	B	96" (2445)
Total height	H	132" (3355)
Wheel base	A	141.5" (3595)
Width of tires	Y	68.7" (1744)
Diameter of tires	R	42" (1070)