

Reliability in Action

Wheeled Loader LG936L



Wheeled Loader LG936L



LG936L

The LG936L is a 10.7 tonne wheeled loader equipped with a hydraulic system which enables operators to achieve smooth and precise control. This, combined with a comfortable cab and good visibility, makes the LG936L a highly productive machine with best-in-class fuel efficiency. All SDLG wheeled loader models are rigorously tested to ensure reliability in action.

- The box structure frame of the LG936L gives best-in-class robustness.
- The access panels on the rear of the machine swing outwards to make daily checks and maintenance much easier.
- Single joystick operation of loader arm and bucket for easy and comfortable operation.

There is a wide range of attachments available for the LG936L including:

- Different size standard buckets
- Side tip bucket
- Multi-function bucket (4-in-1)
- Pallet forks
- Log grapples
- Snow blade
- Attachment bracket and associated attachments

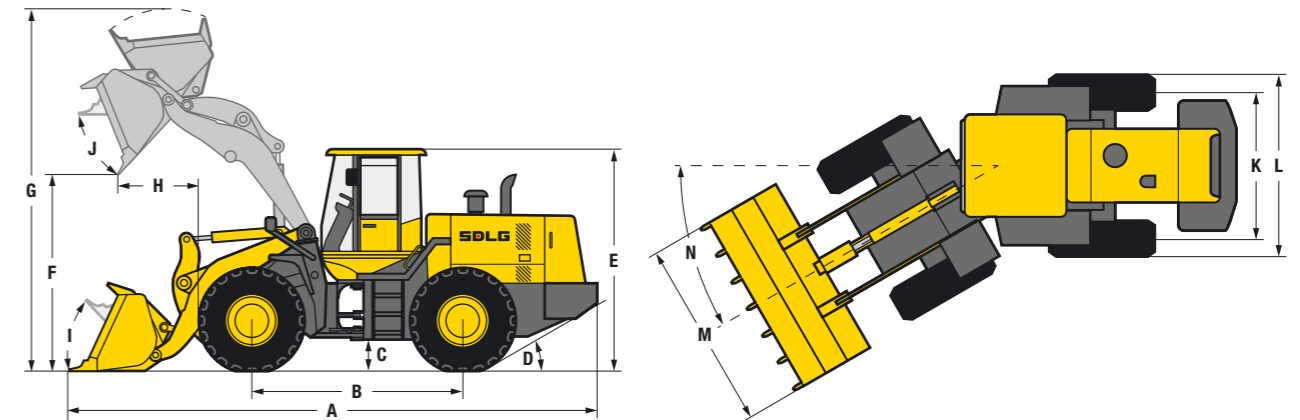

Description	Specification
Operating weight	10 700 kg
Standard bucket capacity	1.8 m ³
Lift capacity (rated load)	3 000 kg
Static tipping load at full turn	6 728 kg
Maximum breakout force	96 kN

Dimensions	
A. Overall length	7 100 mm
B. Wheel base	2 850 mm
C. Ground clearance	370 mm
D. Approach angle back	30°
E. Overall height	3 170 mm
F. Dump height	2 950 mm
G. Overall operating height	4 877 mm
H. Dump reach	1 050 mm
I. Roll back angle ground level	45°
J. Roll back level full height	62°
K. Track width	1 865 mm
L. Machine width	2 310 mm
M. Bucket width	2 510 mm
N. Steering angle	38°

Engine	
Model	Weichai Deutz WP6G125E22
Type	Watercooled, 4 stroke, 6 cylinders in line, direct injection, turbo charged
Rated power (SAE J1349)	97kW @ 2 200 rpm
Maximum torque	500 Nm
Cylinder bore stroke	105 / 120 mm

Description	Specification
Transmission	
Type	Countershaft-type, power shift
Number of gears	2 forward, 1 reverse
Maximum travel speed	Forward 38 km/h Reverse 17 km/h
Drive type	4 wheel drive
Tyre dimension	17.5 - 25
Tyre pressure	Front 48 - 51 psi Rear 40 - 43 psi
Service brake type	Dry disc brake
Parking brake	Dry disc brake

Service fill capacities	
Fuel	140 L
Hydraulic oil	128 L
Axles (main and final drives)	2 × 18 L
Engine	17.5 L
Transmission	45 L
Brake system	4 L
Hydraulics	
Type	Single lever hydraulic pilot control
Boom lift time	5.3 sec
Total cycle time	9.2 sec



SDLG machines are built to be like the people that own them: hardworking, genuine and reliable. Cost effective, robust machines with fuel efficient engines that are easy to operate and easy to maintain.

Everything about SDLG is designed to give you the confidence that you can complete the job to a high standard and on schedule. And when you need parts or service, you can trust your SDLG dealer to deliver on our promise.

When you buy SDLG, you're buying reliability: **Reliability in Action.**



www.sdlg.com